

TURBO

Gear-motor for sliding gates



INDEX

1	Safety warnings	pag. 10
2	Product overview	pag. 12
2.1	Product description	pag. 12
2.2	Model and technical characteristics	pag. 12
3	Preliminary checks	pag. 13
4	Product installation	pag. 14
4.1	Installing	pag. 14
4.2	Fixing	pag. 14
4.3	Rack assembling	pag. 14
4.4	Limit switch fixing	pag. 14
4.5	Manual running	pag. 14
5	Testing and commissioning	pag. 15
5.1	Testing	pag. 15
5.2	Commissioning	pag. 15
6	Figures	pag. 51
7	EC Declaration of Conformity	pag. 55

1 - SAFETY WARNINGS

ATTENTION !

ORIGINAL INSTRUCTIONS - important safety instructions. Follow the instructions since incorrect installation can lead to severe injury! Save these instructions.

Read the instructions carefully before proceeding with installation.

The design and manufacture of the devices making up the product and the information in this manual are compliant with current safety standards. However, incorrect installation or programming may cause serious injury to those working on or using the system. Compliance with the instructions provided here when installing the product is therefore extremely important.

If in any doubt regarding installation, do not proceed and contact the Key Automation Technical Service for clarifications.

Under European legislation, an automatic door or gate system must comply with the standards envisaged in the Directive 2006/42/EC (Machinery Directive) and in particular standards; EN 12453; EN 12635 and EN 13241-1, which enable declaration of presumed conformity of the automation system.

Therefore, final connection of the automation system to the electrical mains, system testing, commissioning and routine maintenance must be performed by skilled, qualified personnel, in observance of the instructions in the "Testing and commissioning the automation system" section.

The aforesaid personnel are also responsible for the tests required to verify the solutions adopted according to the risks present, and for ensuring observance of all legal provisions, standards and regulations, with particular reference to all requirements of the EN 12453 standard which establishes the test methods for testing door and gate automation systems.

ATTENTION !

Before starting installation, perform the following checks and assessments:

ensure that every device used to set up the automation system is suited to the intended system overall. For this purpose, pay special attention to the data provided in the "Technical specifications" section. Do not proceed with installation if any one of these devices is not suitable for its intended purpose;

check that the devices purchased are sufficient to guarantee system safety and functionality;

perform a risk assessment, including a list of the essential safety requirements as envisaged in Annex I of the Machinery Directive, specifying the solutions adopted. The risk assessment is one of the documents included in the automation system's technical file. This must be compiled by a professional installer.

Considering the risk situations that may arise during installation phases and use of the product, the automation system must be installed in compliance with the following safety precautions:

never make modifications to any part of the automation system other than those specified in this manual. Operations of this type can only lead to malfunctions. The manufacturer declines all liability for damage caused by unauthorised modifications to products;

if the power cable is damaged, it must be replaced by the manufacturer or its after-sales service, or in all cases by a person with similar qualifications, to prevent all risks;

do not allow parts of the automation system to be immersed in water or other liquids. During installation ensure that no liquids are able to enter the various devices; should this occur, disconnect the power supply immediately and contact a Key Automation Service Centre. Use of the automation system in these conditions may cause hazards;

never place automation system components near to sources of heat or expose them to naked lights. This may damage system components and cause malfunctions, fire or hazards;

ATTENTION !

The drive shall be disconnected from its power source during cleaning, maintenance and when replacing parts. If the disconnect device is not in a visible location, affix a notice stating: "MAINTENANCE IN PROGRESS":

connect all devices to an electric power line equipped with an earthing system;

the product cannot be considered to provide effective protection against intrusion. If effective protection is required, the automation system must be combined with other devices;

the product may not be used until the automation system "commissioning" procedure has been performed as specified in the "Automation system testing and commissioning" section;

the system power supply line must include a circuit breaker device with a contact gap allowing complete disconnection in the conditions specified by class III overvoltage;

use unions with IP55 or higher protection when connecting hoses, pipes or cable glands;

the electrical system upstream of the automation system must comply with the relevant regulations and be constructed to good workmanship standards;

this appliance can be used by children aged from 8 years and above and persons with reduced physical, sensory or mental capabilities or lack of experience and knowledge if they have been given supervision or instruction concerning use of the appliance in a safe way and understand the hazards involved;

before starting the automation system, ensure that there is no-one in the immediate vicinity;

before proceeding with any cleaning or maintenance work on the automation system, disconnect it from the electrical mains;

special care must be taken to avoid crushing between the part operated by the automation system and any fixed parts around it;

children must be supervised to ensure that they do not play with the equipment;

that the drive cannot be used with a driven part incorporating a wicket door unless the drive can only be operated with the wicket door in the safe position;

install any fixed control at a height of at least 1,5m and within sight of the door but away from moving parts;

after installation, ensure that parts of the door do not extend over public footpaths or roads;

when the appliance is provided with a separate stop button, that stop button shall be unambiguously identifiable;

install the automation exclusively on gates operating on flat surfaces, that is, they are not installed on an up or down tilt;

install exclusively on gates that are sturdy enough and suitable to withstand the loads generated by the automation itself;

do not subject the automation to direct jets of water, such as sprinklers or pressure washers;

if the automation system exceeds 20 kg in weight, it must be handled using safety lifting devices (IEC 60335-2-103: 2015);

provide appropriate safety protections in order to avoid crushing and becoming trapped between the moving guided part and any surrounding fixed elements;

make sure that any protection or safety devices, in addition to the manual release, work correctly;

place the automation identification plate at a clearly visible point;

keep the manuals and technical files of all the devices used to create the automation;

at the end of the automation installation it is advisable to hand over the manuals relating to the warnings intended for the end user;

ATTENTION !

Frequently examine the installation for imbalance where applicable and signs of wear or damage to cables, springs and mounting. Do not use if repair or adjustment is necessary.

ATTENTION !

The automation system component packaging material must be disposed of in full observance of current local waste disposal legislation.

Key Automation reserves the right to amend these instructions if necessary; they and/or any more recent versions are available at www.keyautomation.it.

2 - PRODUCT OVERVIEW

2.1 - Product description

Irreversible electromechanical gearmotor for sliding gates operating at 24 Vdc and 230 Vac. (Fig.1)

2.2 - Model and technical characteristics

CODE	DESCRIPTION
SC162	230 Vac gear motor with mechanical limit switches, gate maximum weight 1600 kg

TECHNICAL DATA

MODEL		SC162
Speed*	cm/s	16
Torque	Nm	40
Working cycle	%	30
Control unit		CT102B
Power	Vac (Vdc)	230
Motor consumption	A	3
Consumption power	W	700
Capacitor	μF	20
Thermoprotection	°C	150
Protection degree	IP	44
Dimension (L - P- H)	mm	320 - 184 - 260
Weight	Kg	14,5
Working temperature	°C	-20 +55
Max gate weight	Kg	1600
Sound emission level	dB(A)	≤ 70

3 - PRELIMINARY CHECKS

Before installing this product, verify and check the following steps:

- Check that the gate or door are suitable for automation
- The weight and size of the gate or door must be within the maximum permissible operating limits specified in Fig. 2
- Check the presence and strength of the security mechanical stops of the gate or door
- Check that the mounting area of the product is not subject to flooding
- Conditions of high acidity or salinity or proximity to heat sources could cause malfunction of the product
- Extreme weather conditions (for example the presence of snow, ice, high temperature range, high temperatures) may increase the friction and therefore the force required for the handling and initial starting point may be higher than under normal conditions.
- Check that the manual operation of gate or door is smooth and friction-free and there is no risk of derailment of the same
- Check that the gate or door are in equilibrium and stationary if left in any position

- Check that the power line to supply the product is equipped with proper grounding safety and protected by a magnetothermal and differential security device
- Provide the power system with a disconnecting device with a gap of contacts enabling full disconnection under the conditions dictated by the overvoltage category III.
- Ensure that all materials used for the installation comply with current regulations

4 - PRODUCT INSTALLATION

4.1 - Installation

ATTENTION !

The installer must verify that the working temperature range stated on the automation device is suitable for the location where it is installed.

ATTENTION !

The automation system must be equipped with a pressure-sensitive edge protecting all possible crushing points (hands, feet, etc.) in accordance with the requirements of the EN 13241-1 standard.

ATTENTION !

The gate has to be equipped with stop locks at the opening and closing, which prevent the gate derailment.

Respecting the overall size, fix to ground the base-plate through 4 sturdy screw-anchors (fig.3) or drown it into the concrete (fig.3). Plan for one or more sheathing for the passage of the power lines.

N.B. The exact dimensions of the rack must be known to allow precise calculation of the counterplate position.

Fig.2 is an example of a typical system:

- Post for photocells (1)
- Automation electromechanical (2)
- Photocell detectors (3)
- Flashing light (4)
- Key switch (5)
- Radio transmitter (6)
- Pressure-sensitive edge (7)

4.2 - Fixing

Take the lid off unscrewing the screws (fig.4.1). Put the gearmotor on the plate. Insert the two socket head screws (fig.4.2).

It is important to lock the two socket head screws forcefully, making sure, that the gearmotor is firmly on the ground, during the whole movement/operation of the gate.

If the regulating allowed by the rack is not sufficient, it is possible to counterbalance the gearmotor high working on the four screws (fig.4.3).

The screws should be tightened again after the motor has been operated a few times.

4.3 - Rack assembling

Release the gearmotor as indicated by the fig.7 and open entirely the gate. Put a rack element on the pinion gear and fasten it to the gate with screw and spacing bars.

Move the gate manually bringing the pinion gear into line with the last spacing bar.

Fasten the rack element for good.

For a correct positioning of the other elements and to assure their straightness, it is necessary to employ a rack element using it as support and reference (fig.5.2).

It is besides necessary to assure an aperture of 2 mm between rack and pinion gear, so that the gate weight doesn't rest on the gearmotor pinion gear (fig.5.1).

4.4 - Limit switch fixing

The gate has to be equipped with stop locks at the opening and closing, which prevent the gate derailment.

The stop lock position must assure that the limit switch brackets don't collide with the pinion gear.

Haul the gate manually at the opening leaving, depending on the

gate weight, a crack from 30 to 50 mm between the main gate and mechanical stop.

Fasten the limit switch bracket through the dowels (fig.6.2) so that the limit switch is pressed (fig.6.1).

Repeat the operation with the main gate at the closing.

4.5 - Manual running

Insert the key and turn it 90° in anticlockwise direction. (Fig.7)
Pull the knob till it is perpendicular to the gearmotor.

ATTENZIONE !

Take care to re-engage the gearmotor before starting it up. Engaging with the motor running may damage its internal components.

5 - TESTING AND COMMISSION THE AUTOMATION

The system must be tested by a qualified technician, who must perform the tests required by the relevant standards in relation to the risks present and must check that the installation complies with

the relevant regulatory requirements, especially with the EN12453 standard which specifies the test methods for gate and door automation systems.

5.1 - Testing

All the system components must be tested following the procedures described in their respective operator manuals;

ensure that the recommendations in Chapter 1 – Safety Warnings - have been complied with;

check that the door can move freely once the automation is released and that it is in balance and therefore remains stationary if left in any position;

check that all the connected devices (photocells, sensitive edges, emergency buttons, etc.) are operating correctly by performing door opening, closing and stop tests using the connected control devices (transmitters, buttons or switches);

perform the impact measurements as required by the EN12453 standard, adjusting the control unit's speed, motor force and deceleration functions if the measurements do not give the required results, until the correct setting is obtained.

5.2 - Commissioning

Once all (and not just some) of the system devices have passed the testing procedure, the system can be commissioned;

the system's technical dossier must be produced and kept for 10 years. It must contain the electrical wiring diagram, a drawing or photograph of the system, the analysis of the risks and the solutions adopted to deal with them, the manufacturer's declaration of conformity for all connected devices, the operator's manual for every device and the system maintenance plan;

fix a plate on the door indicating the automation data, the name of the person responsible for commissioning, the serial number, the year of construction and the CE mark;

also fit a plate specifying the procedure for releasing the system by hand;

draw up the declaration of conformity, the instructions and precautions for use for the end user and the system maintenance plan and consign them to the end user;

ensure that the user has fully understood how to operate the system in automatic, manual and emergency modes;

the end user must also be informed in writing about any risks and hazards still present;

ATTENTION !

After detection of an obstacle, the door stops on opening and automatic closing is excluded; to resume movement, press the control button or use the transmitter.

IMAGES

Fig. 1
EN - Product description

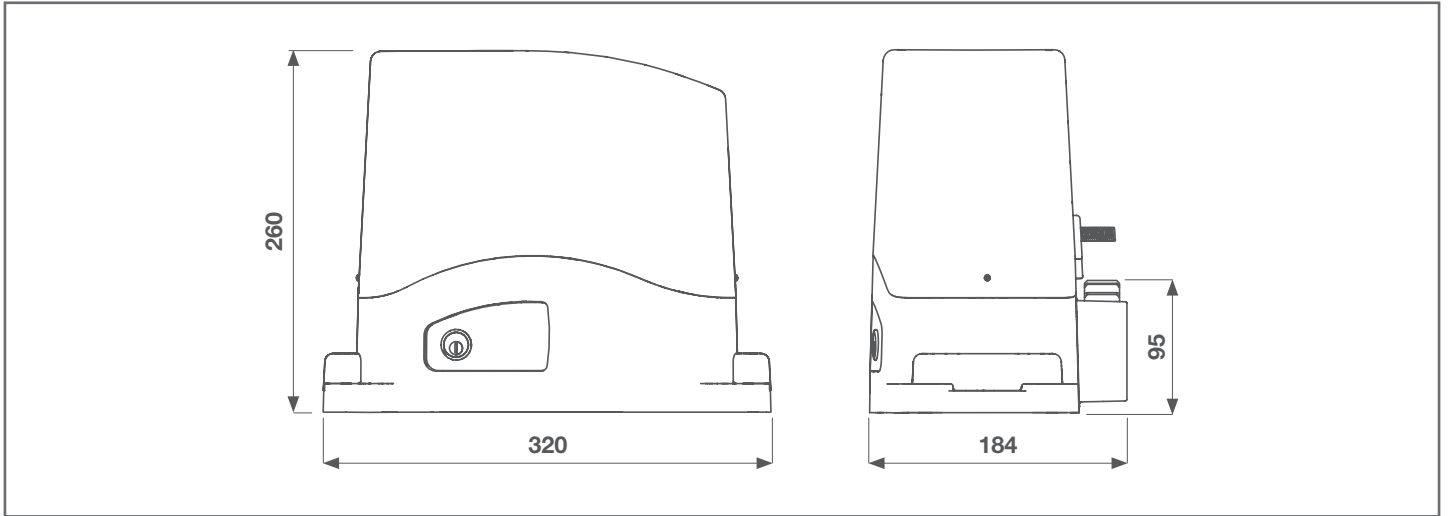

Fig. 2
EN - Typical Installation

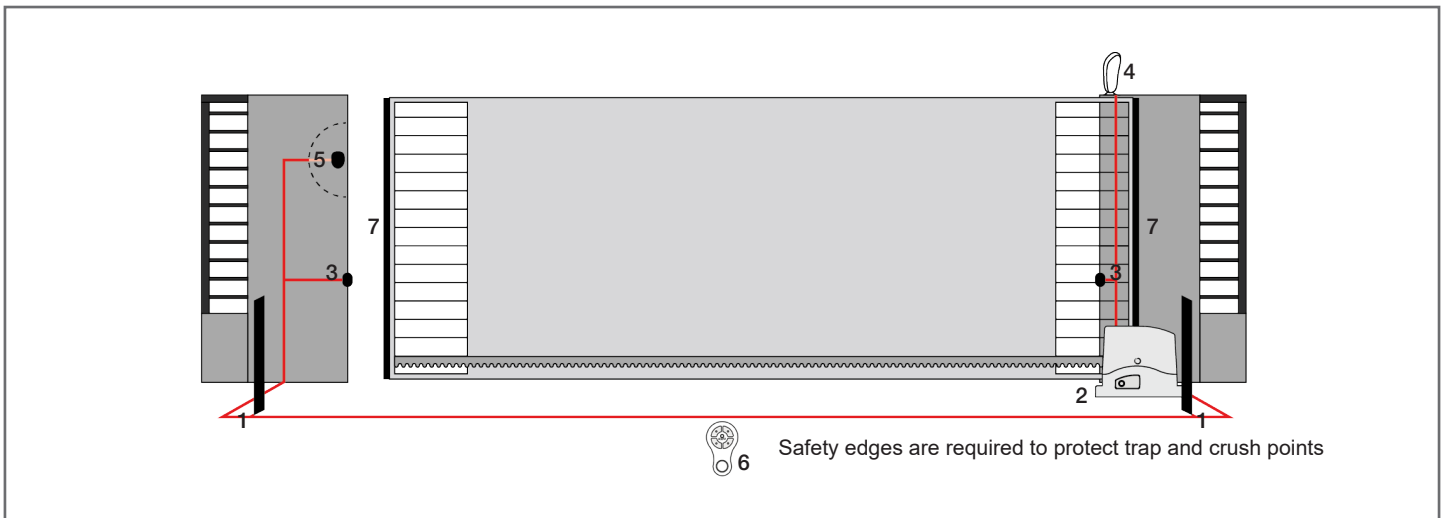

Fig. 3
EN - Installing

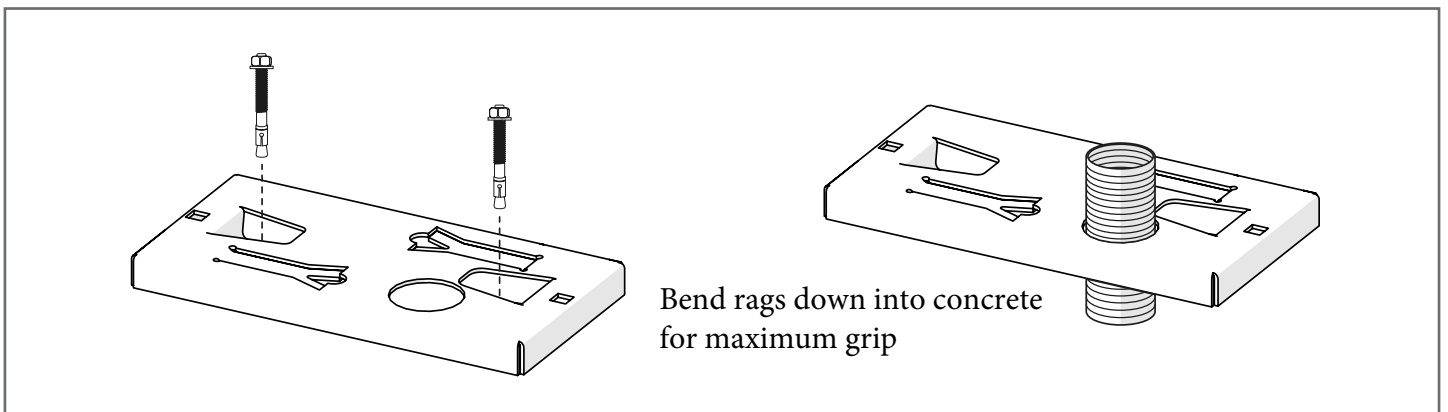

Fig. 4
EN - Fixing

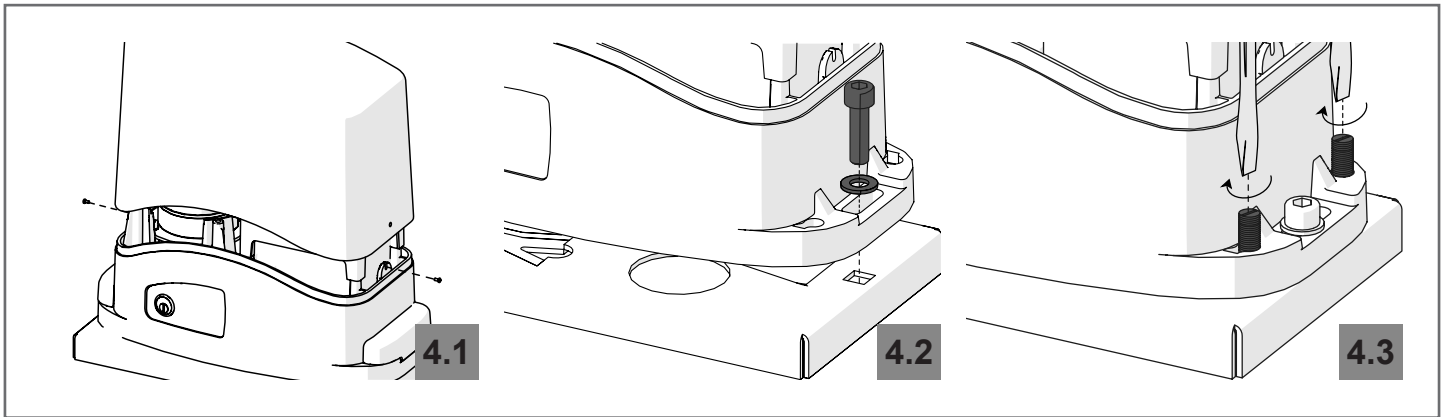

Fig. 5
EN - Rack assembling

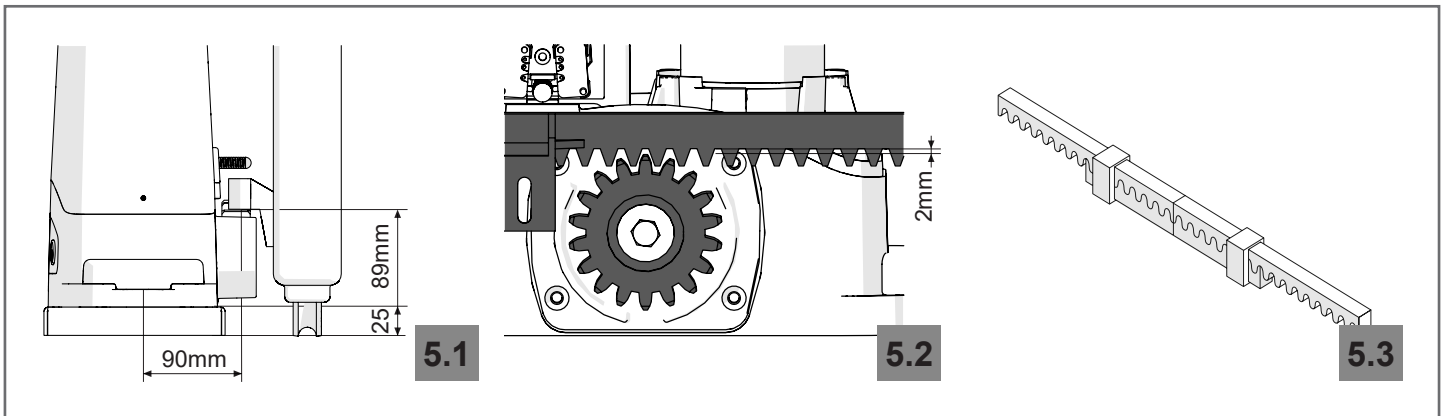

Fig. 6
EN - Limit switch fixing

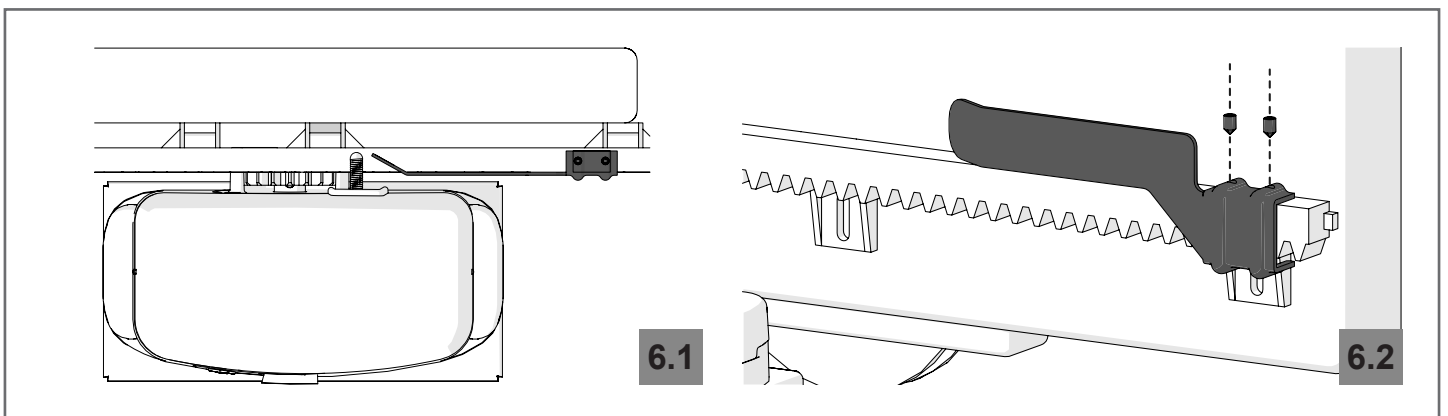
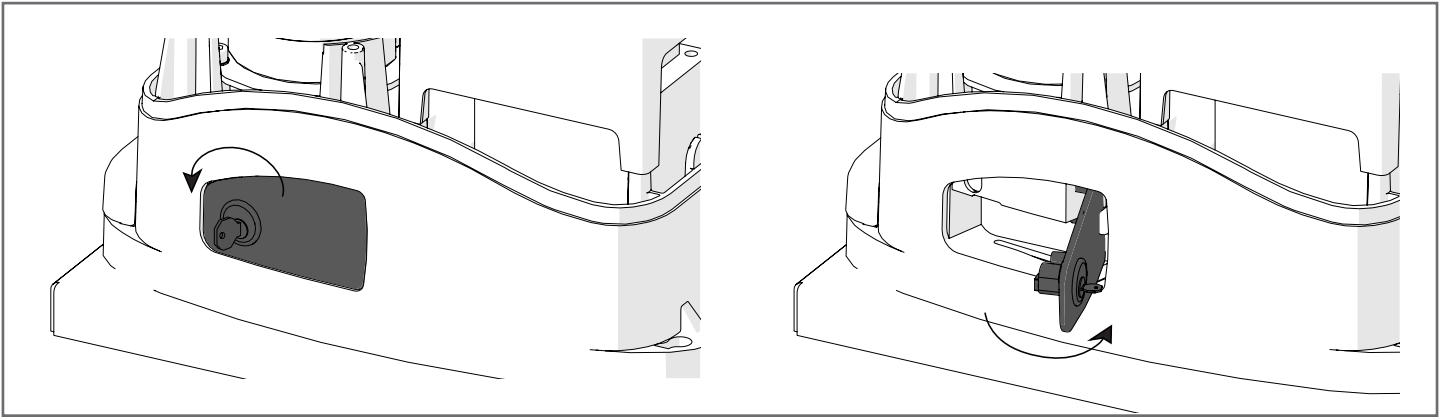

Fig. 3
EN - Emergency unlocking



DICHIARAZIONE DI INCORPORAZIONE DI QUASI-MACCHINA DECLARATION OF INCORPORATION OF PARTLY COMPLETED MACHINERY

Il sottoscritto Nicola Michelin, Amministratore Delegato dell'azienda
The undersigned Nicola Michelin, General Manager of the company

Key Automation S.r.l., Via Meucci, 23 - 30027 San Donà di Piave (VE) – ITALIA

dichiara che il prodotto tipo:
declares that the product type:

TURBO

Motoriduttore elettromeccanico irreversibile per cancelli scorrevoli da 400kg a 1600kg
Electromechanical irreversible gear motor for sliding gates from 400kg to 1 600kg

Models:
Models:

SC52, SC52M, SC82, SC82M, SC122, SC122M, SC162, SC162M
SC4224, TU7224, TU7224M, TU11224, TU11224M

E' conforme a quanto previsto dalle seguenti direttive comunitarie:
Is in conformity with the following community (EC) regulations:

Direttiva macchine / *Machinery Directive 2006/42/EC*
Direttiva compatibilità elettromagnetica / *EMC Directive 2014/30/EU*
Direttiva bassa tensione / *Low voltage Directive 2014/35/EU*
Direttiva radiofrequenza / *RED Directive 2014/53/EU*
Direttiva RoHS / *RoHS Directive 2011/65/UE*

Secondo quanto previsto dalle seguenti norme armonizzate:
In accordance with the following harmonized standards regulations:

ETSI EN 301489-3:2013, ETSI EN 301489-1:2011
EN 60950-1:2006 + A11:2009 + A1:2010 + A12:2011 + A2:2013
EN 61000-3-2:2014, EN 61000-3-3:2013
EN 61000-6-2:2005, EN 61000-6-3:2007
EN 60335-1:2012 + A1 + A11; EN 60335-2-103:2015
EN 55014-1:2006 + A1 + A2; EN 55014-2:2015
EN 62233:2008

Dichiara che la documentazione tecnica pertinente al prodotto è stata redatta conformemente a quanto previsto dalla direttiva 2006/42/CE Allegato VII parte B e verrà fornita a fronte di una richiesta adeguatamente motivata dalle autorità nazionali.

Declares that the technical documentation is compiled in accordance with the directive 2006/42/EC Annex VII part B and will be transmitted in response to a reasoned request by the national authorities.

Dichiara altresì che non è consentita la messa in servizio del prodotto finché la macchina, in cui il prodotto è incorporato, non sia stata dichiarata conforme alla direttiva 2006/42/CE.

He also declares that is not allowed to use the above mentioned product until the machine, in which this product is incorporated, has been identified and declared in conformity with the regulation 2006/42/EC.

San Donà di Piave (VE), 21/02/17

Amministratore Delegato
General Manager
Nicola Michelin



Key Automation S.r.l.
Via Meucci, 23
30027 San Donà di Piave (VE)
P.IVA 03627650264 C.F. 03627650264
info@keyautomation.it

Capitale sociale 154.000,00 i.v.
Reg. Imprese di Venezia 03627650264
REA VE 326953
www.keyautomation.it



Organizzazione con sistema di gestione certificato
ISO 9001:2008

Key Automation S.r.l.

Via Meucci 23 - 30027 San Donà di Piave (VE)

T. +39 0421 307456 - F. +39 0421 65698

info@keyautomation.it - www.keyautomation.it

Instruction version

580ISSC-50 REV.08